



INDICATIVE PHOTO

General features : RCS2250606

RCS range unit coolers have been designed to be installed inside cold rooms suited for fresh and frozen goods storage

Their shape, being extremely compact, make their installation possible also in cold rooms having very small dimensions

RCS range is available in different combinations of fin spacing dimensions and tube rows properly sized according to the needed applications.

The ED version is supplied with mounted defrosting heaters and is suitable for being used at low temperature applications.

The fan motors operate in the suction mode and prevent the condensate forming on the fan

The coil is made of aluminium fins, 12 mm copper tube and a geometry of 37,5 x 32,5

RCS unit coolers can be classified in three groups according to the needed cold room temperature (Tc): 4mm fin spacing for a Tc from -5°C to +15°C; 6mm fin spacing for a Tc from -20°C to +15°C; 8mm fin spacing for a Tc from -40°C to +4°C

Each fin spacing group is also available with 4 and 6 rows.

The coils are tested with nitrogen at a pressure of 25 bar.

The fan motor models in use have the following features:

Manufactured following EN 60335-1 laws, with internal thermal protection

Fan diameter 250mm

Power supply 230-240V/1/50-60Hz

IP44 protection rate

F insulation class

Operating temperature from -40°C to +40°C

Electrics made in conformity with 2006/95/CE Low Tension directive

The housing is made of aluminium

The manufacturing solutions used give the housing strength and guarantee the absence of vibrations during the functioning.

Screws, washers and nuts are made of stainless steel



INDICATIVE PHOTO

Product file : Unit coolers

Code	RCS2250606ED
Model	Ceiling cubic unit cooler
Range	RCS
Application	MBP
Net weight	23,2 kg
Inlet connection	12 mm-1/2" SAE
Outlet connection	16 mm
Drain connection	1" Gas (33mm)
Ped	0
Rows	6
Fin spacing	6
Circuit volume	4,75 dm ³
Total surface	14,4 m ²

Fan motor

Fans no.	2
Diameter	254 mm
Power supply	230/1/50
Defrost	1350 W
Speed	1300 rpm
Power consumption	160 W
Current consumption	0,7 A
Air flow	1575 m ³ /h
Air throw	9 m

Technical drawing - RCS2250606

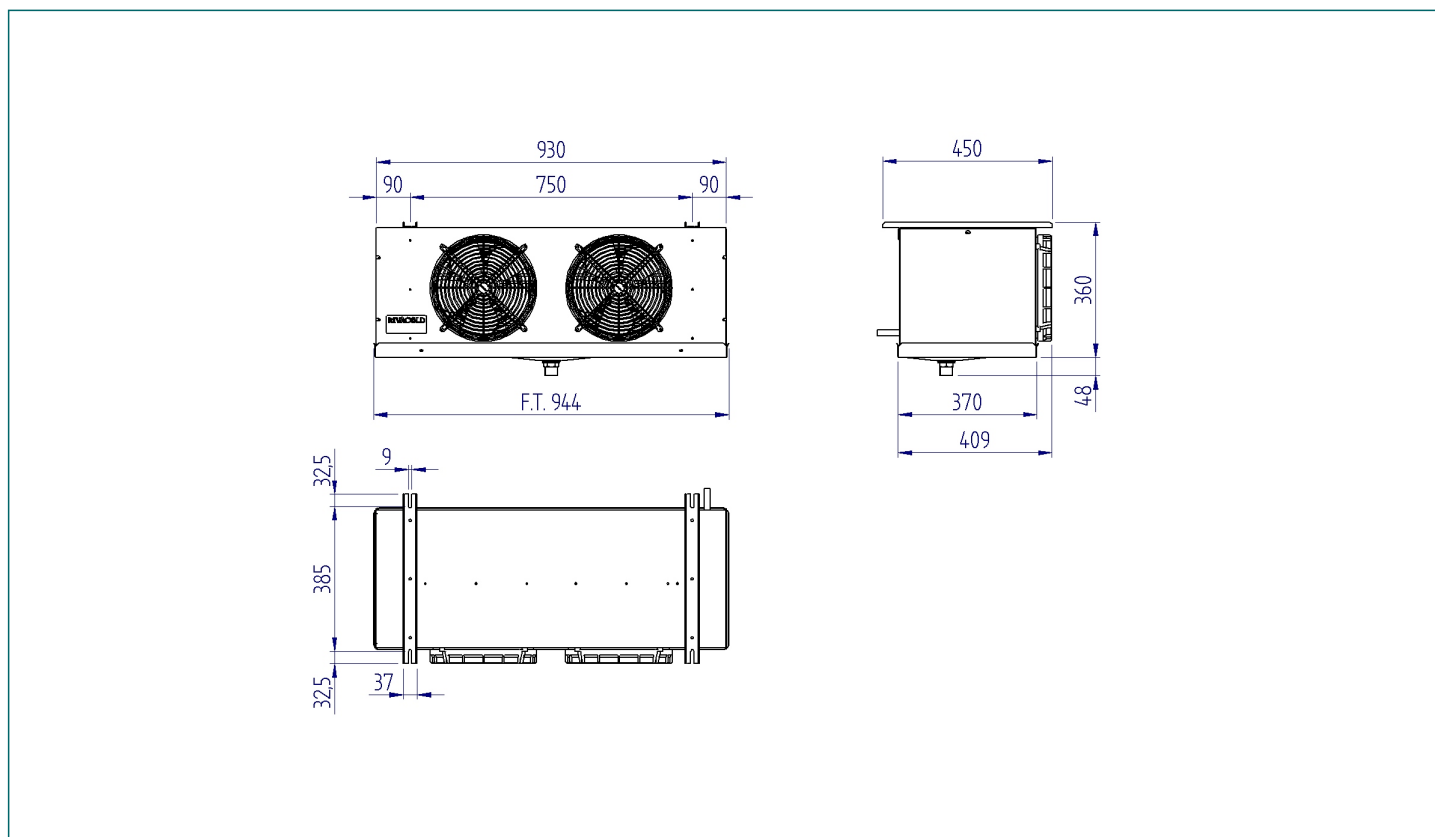

Refrigerating capacity table (watt) - Gas : R404A

dT \ Tc	-20°C	-15°C	-10°C	-5°C	0°C	2°C	4°C	6°C	8°C	10°C	12°C	15°C
10	2560 ⁽¹⁾	2800	2980	3210	3450	3510	3620	3660	3710	3790	3910	4090
9	2350 ⁽¹⁾	2550	2710	2910	3120	3170	3210	3250	3290	3390	3470	3590
8	2120 ⁽¹⁾	2290	2420	2590	2780	2810	2830	2860	2910	3010	3080	3185
7	1870 ⁽¹⁾	1980	2110	2250	2410	2430	2450	2500	2550	2610	2670	2760
6	1600 ⁽¹⁾	1680	1790	1910	2060	2080	2100	2130	2190	2250	2310	2400
5	1300 ⁽¹⁾	1370	1460	1560	1690	1710	1740	1770	1820	1880	1940	2030

(1) Applicazione fuori dal campo consigliato